

Jammer Suppression in DS-CDMA Arrays Using Independent Component Analysis

K. Raju, T. Ristaniemi, J. Karhunen, and E. Oja

Abstract— We propose using Independent Component Analysis (ICA) as an advanced pre-processing tool for blind suppression of interfering jammer signals in direct sequence spread spectrum communication systems utilizing antenna arrays. The role of ICA is to provide a jammer-mitigated signal to the conventional detection. If the jammer signal is weak or absent, preprocessing by ICA is not advisable. Therefore we also consider two possible switching schemes, called pre-switching and post-switching, which activate the ICA-based jammer canceller only when it is expected to improve conventional detection. ICA-RAKE pre-switching is less complex, while post-switching performs better, especially when the jammer is pulsed in nature. Simulations are given to illustrate the achieved performance gains for single- and multi-path channels.

Index Terms— Jammer mitigation, bit-pulsed jamming, interference cancelation, code-division multiple access, blind source separation, independent component analysis.

I. INTRODUCTION

INTERFERENCE and jammer mitigation techniques [1], [9], [11] have been studied actively in spread spectrum (SS) communications, because they improve the overall system performance and capacity without the need for a wider spectrum. This paper deals with interference (jammer) suppression for direct sequence code division multiple access (DS-CDMA) systems [20]. In commercial cellular SS and DS-CDMA systems, many types of interference can appear, starting from multiuser interference inside each sector in a cell to inter-operator interference. Unintentional jamming can also be present due to co-existing systems at the same band, whereas intentional jamming arises mainly in military applications.

In DS-CDMA systems, the conventional matched filter (MF) based RAKE receiver [12] is used widely in practice when multi-path scenario is present. This is because it is usually more robust against model imperfections and nonstationarities than more sophisticated receiver structures discussed for example in [10], [19]. However, RAKE is based only on the processing gain and frequency diversity, and hence it is vulnerable in the presence of jamming.

Jamming can be mitigated by the use of multiple antenna sensors utilizing spatial diversity. However, when using conventional array receivers, directions of arrivals of signals must

be estimated first. This in turn requires exact prior knowledge of the positions of the receiving antenna sensors. Blind techniques [2], [6], [7], [8] relax this stringent requirement, making it possible to achieve performance gains when applied to uncalibrated arrays in which the positions of the sensors are known only roughly or not at all. Most blind techniques are based on the assumption that the original source signals are statistically independent of each other. This assumption is quite realistic here, because the jammer signal originates from a different physical source than the information bearing signal.

Belouchrani and Amin [2], [3] were the first to present the idea of applying blind source separation (BSS) techniques to aid conventional detection. They have used BSS techniques based on second-order statistics to separate a set of independent information signals from their mixtures observed at the sensors. However, their work suffers from some weaknesses. To work properly the receiver in [2] requires temporally correlated information and jamming signals. Hence, their scheme is inadequate in the presence of data modulation. Furthermore, resorting to second-order temporal statistics only makes the scheme vulnerable to signals having low temporal correlations. Such cases are commonplace in DS-CDMA communication systems, appearing for example when the jamming signal is pulsed in nature or not locked to the carrier frequency.

In this paper, we extend the framework proposed in [2] in three respects. Firstly, we apply BSS techniques based on independent component analysis (ICA) [8] instead of temporal correlations. ICA takes into account also higher-order statistics by forcing statistical independence of the separated signals. This enables jammer suppression for different types of jammer signals under realistic conditions¹. Secondly, we propose a hybrid receiver structure in which the ICA-based pre-processing is activated only when it is expected to improve the performance of the whole receiver chain. Finally, we propose different switching criteria between ICA and RAKE branches in the receiver chain and evaluate their effects to the performance of the receiver. The evaluation is carried out in an AWGN channel with external jamming, which is temporally uncorrelated at the symbol level. Because of AWGN channel a one-finger RAKE, that is, matched filter, is used.

This article presents in a unified form the central results of preliminary conference papers [13], [14], [17], [18].

Manuscript received October 9, 2002; revised December 4, 2003, September 20, 2004, and December 20, 2004; accepted February 3, 2005. The associate editor coordinating the review of this letter and approving it for publication was H. Yanikomeroglu.

K. Raju, J. Karhunen, and E. Oja are with Helsinki University of Technology, Neural Networks Research Centre, P.O.Box 5400, FIN-02015 HUT, Espoo, Finland (e-mail: karthik@james.hut.fi, {Juha.Karhunen, Erkki.Oja}@hut.fi).

T. Ristaniemi is with Tampere University of Technology, Institute of Communication Engineering, P.O. Box 553, FIN-33101 Tampere, Finland (e-mail: Tapani.Ristaniemi@tut.fi).

Digital Object Identifier 10.1109/TWC.2006.01006.

¹Belouchrani and Amin have in [3] briefly compared an ICA method called JADE (see for example [8]) with their second-order techniques in jammer mitigation, getting roughly equal results. The sources in their comparison were temporally correlated. In this paper, the type of jamming is slightly different. Namely, the jammer is temporally uncorrelated at the symbol level due to the bit-pulsed nature of the jammer. As a consequence, all the samples (T_c seconds apart) of the jamming signal within one symbol interval are temporally correlated, but any two samples apart more than T seconds are uncorrelated.

II. JAMMER SIGNALS IN DS-CDMA ARRAYS

A standard spread spectrum system [20] with direct sequence spreading is assumed. Without loss of generality, we consider here a downlink channel (for example base-to-mobile). If only one antenna sensor is used in the reception, the data describing the received block of M symbols via AWGN channel is of the form [10], [19]

$$r(t) = \sum_{m=1}^M \sum_{k=1}^K a b_{km} s_k(t - mT - dT_c) + n(t) \quad (1)$$

where the symbols b_{km} are sent to K users via a channel characterized by a complex path gain a and a path delay dT_c . Here T_c is the duration of a chip, and d is discrete, $d \in \{0, \dots, (C-1)/2\}$, where $C = T_c/T$ is the processing gain. The delay is assumed to remain constant for every block of M data symbols. Furthermore, $s_k(\cdot)$ is k th user's binary chip sequence, supported by $[0, T)$, where T is the symbol duration, and $n(t)$ is Gaussian noise [19], [20].

The received signal $r(t)$ in (1) is jammed by a signal $j(t)$, which has the form

$$j(t) = \delta_p(t) \sqrt{J} e^{i(2\pi f_j t + \phi)} \quad (2)$$

where $i = \sqrt{-1}$. The quantity $\delta_p(t) = 1$ with a probability p during a symbol. Jamming corresponds to a continuous wave when $p = 1$ and pulsed wave at the symbol level otherwise. These two cases are used as examples of narrow-band and wide-band jamming². The power, frequency, and phase of the jammer signal $j(t)$ are denoted respectively by J , f_j , and ϕ . The phase is assumed to be uniformly distributed over the interval $[0, 2\pi)$.

Assuming an antenna array, the received signal at the n th antenna element ($n = 1, \dots, N$) before the down-conversion can be written as

$$u_n(t) = r(t) e^{i2\pi f_c t} e^{i(n-1)\theta_r} + j(t) e^{i(n-1)\theta_j} \quad (3)$$

where $r(t)$ is the baseband spread spectrum signal (1) that is DSB modulated at a carrier frequency f_c . Variables θ_r and θ_j are related to the directions of arrival of the information signal $r(t)$ and the jammer signal $j(t)$ respectively, and their form depends on the antenna configuration.

This signal is down-converted to the baseband³, yielding

$$r_n(t) = u_n(t) e^{-i2\pi f_c t} = r(t) e^{i(n-1)\theta_r} + \delta_p(t) \sqrt{J} e^{i(2\pi(f_j - f_c)t + \phi)} e^{i(n-1)\theta_j} \quad (4)$$

Thus the bit-pulsed jammer introduces a bias with a constant amplitude, but with a varying phase determined by the frequency offset. If the jammer is locked to the carrier frequency so that $f_j = f_c$, then the contribution of the jammer reduces to $\delta_p(t) \sqrt{J} e^{i\phi} e^{i(n-1)\theta_j}$. This means that the phase of the bias is determined by the direction of arrival θ_j of the jammer signal and the initial phase difference ϕ of the carrier and jammer's tone.

²Also chip-pulsed jamming could have been considered as an example of wide-band jamming.

³Baseband model is assumed for simplicity. In fact, the ICA-based scheme would just need band-pass filtering for the received signal (bandwidth equal to that of information bearing signal component) after which ICA is able to separate the two components.

Using this definition the received antenna data $r_1(t), \dots, r_N(t)$ can be represented more concisely in vector form as

$$\mathbf{r}(t) = \Theta \mathbf{z}(t) + \mathbf{n}(t) \quad (5)$$

where the vector

$$\mathbf{r}(t) = [r_1(t) \ r_2(t) \ \dots \ r_N(t)]^T \quad (6)$$

contains the signals received at the N array elements at time t ,

$$\mathbf{z}(t) = [r(t) \ j(t) e^{-i2\pi f_c t}]^T \quad (7)$$

is a two-component vector having as its elements the information signal $r(t)$ and down-converted jammer signal $j(t)$ at time t , and the array steering matrix

$$\Theta = \begin{bmatrix} 1 & 1 \\ e^{i\theta_r} & e^{i\theta_j} \\ \vdots & \vdots \\ e^{i(N-1)\theta_r} & e^{i(N-1)\theta_j} \end{bmatrix} \quad (8)$$

The N -vector $\mathbf{n}(t)$ is similar in form to (6), containing additive white Gaussian noise (AWGN) terms $n_i(t)$ at each antenna element $i = 1, 2, \dots, N$.

III. INDEPENDENT COMPONENT ANALYSIS

Independent Component Analysis (ICA) [8] is a fairly new, increasingly popular statistical technique. The goal of ICA is to express a set of m observed signals $x_1(t), \dots, x_m(t)$ at time t as linear combinations of n unknown but statistically independent components $s_1(t), \dots, s_n(t)$ called usually sources or source signals. The ICA problem is blind, because not only the source signals but also the mixing coefficients are unknown.

Introducing the data vector $\mathbf{x}(t) = [x_1(t), \dots, x_m(t)]^T$ and the source vector $\mathbf{s}(t) = [s_1(t), \dots, s_n(t)]^T$, the instantaneous noisy linear ICA mixture model is given by

$$\mathbf{x}(t) = \mathbf{A} \mathbf{s}(t) + \mathbf{n}(t) \quad (9)$$

Here, the $m \times n$ unknown but constant mixing matrix \mathbf{A} contains the mixing coefficients, and $\mathbf{n}(t)$ denotes the additive noise vector at time t . We make the standard assumptions that \mathbf{A} has full column rank, and that $n \leq m$, meaning that there are at most as many source signals $s_j(t)$ as mixtures $x_i(t)$ [8].

The source signals $\mathbf{s}(t)$ are estimated using only the observations $\mathbf{x}(t)$ by finding an $n \times m$ unmixing matrix \mathbf{W} such that the n -vector $\mathbf{W} \mathbf{x}(t)$ recovers the original sources as well as possible. Because of the blindness of the problem, only the waveforms of the sources can be estimated. For estimating the unmixing (separating) matrix \mathbf{W} , many different methods have been proposed; see [8] for an extensive discussion.

A comparison of the array signal model (5) with the mixing model (9) shows immediately that (5) is actually a noisy mixing model with a mixing matrix Θ and source vector $\mathbf{z}(t)$. Hence ICA or other BSS techniques can be applied to separation of the information signal and jammer signal. Estimates of these signals are obtained as the components of the vector $\mathbf{W} \mathbf{r}(t)$, but their order and scaling is arbitrary.

In most ICA methods, the data are first pre-whitened spatially, because this makes the subsequent separation task easier

[8]. In whitening, the observed mixtures $\mathbf{r}(t)$ are transformed linearly so that their components become uncorrelated and have unit variance:

$$\mathbf{y}(t) = \mathbf{T}\mathbf{r}(t), \quad \mathbf{E}\{\mathbf{y}(t)\mathbf{y}(t)^H\} = \mathbf{I} \quad (10)$$

Here, $\mathbf{y}(t)$ is the whitened data vector, \mathbf{T} a $N_w \times N$ -dimensional whitening transformation matrix ($N_w \leq N$), \mathbf{I} the $N_w \times N_w$ -dimensional unit matrix, and H denotes complex conjugation and transposition. Whitening is often carried out via principal component analysis (PCA), which yields for complex-valued data the transformation matrix

$$\mathbf{T} = \mathbf{\Lambda}_s^{-\frac{1}{2}} \mathbf{U}_s^H \quad (11)$$

There, the matrices $\mathbf{\Lambda}_s$ and \mathbf{U}_s respectively contain the eigenvalues and eigenvectors of the autocorrelation matrix $\mathbf{E}\{\mathbf{r}(t)\mathbf{r}(t)^H\}$ of the received data vectors $\mathbf{r}(t)$. When PCA is used for whitening, it is easy to reduce the dimensionality of the data vectors simultaneously if desired by using only the principal eigenvectors in $\mathbf{\Lambda}_s$ and \mathbf{U}_s ; see [8] for details.

In our experiments, we applied complex-valued version [4], [8], [15], [16] of the so-called FastICA algorithm to the whitened mixtures $\mathbf{y}(t)$ for separating the sources. The core of this algorithm is updating of the i th column \mathbf{w}_i of the orthogonal separating matrix \mathbf{W} according to [4], [8]

$$\mathbf{w}_i^+ = \mathbf{E}\{\mathbf{y}(t)[\mathbf{w}_i^H \mathbf{y}(t)]^* |\mathbf{w}_i^H \mathbf{y}(t)|^2\} - \gamma \mathbf{w}_i \quad (12)$$

where \mathbf{w}_i^+ is the updated value of \mathbf{w}_i , and $*$ denotes complex conjugation. The constant γ is 2 for complex-valued signals, and 3 for real ones. In practice, the expectation \mathbf{E} in (12) is replaced by computing the respective average over the available set of whitened data vectors $\mathbf{y}(t)$. In addition to (12), the columns of \mathbf{w}_i^+ must be orthonormalized after each step. This can be carried out for example via Gram-Schmidt orthogonalization. FastICA and its different variants are discussed thoroughly in [8]. Instead of FastICA, other ICA algorithms introduced for complex-valued mixtures could be used.

IV. SUPPRESSION OF JAMMING SIGNALS USING ICA AND RAKE

In our jamming problem, RAKE uses prior knowledge on the desired user's code, and it can be applied also when a jammer signal is present. However, RAKE does not exploit independence of the information bearing signal from the jamming signal in any way. On the other hand, ICA relies on the strong but realistic independence assumption, but it is a blind technique which does not take into account the desired user's code and the structure of the array steering matrix (8). In this work, we combine ICA and RAKE sequentially when it is reasonable for utilizing better the available prior information on the considered jamming problem.

The basic ICA-RAKE receiver proposed for jammer signal suppression consists of the three blocks (Preprocessing, ICA & Selection, and RAKE Detection) contained in the dash-dotted rectangle both in Figures 1 and 2. The received vectors $\mathbf{r}(t)$ are first prewhitened, and then the FastICA algorithm (12) is applied to the prewhitened vectors $\mathbf{y}(t)$ as explained in the previous section. Due to the inherent indeterminacies

of ICA [8], two additional tasks must be performed in the basic ICA-RAKE receiver. These are selection of the estimate $\hat{r}(t)$ of the desired information bearing source $r(t)$ among the separated two sources, and estimation of the channel. Notice that in our problem ICA is usually used for separating two sources only, which then provide estimates of the components of the vector $\mathbf{z}(t)$ in (7). Recall that the components of the vector $\mathbf{z}(t)$ are the information bearing signal $r(t)$ and down-converted jammer signal $j(t)$.

ICA can estimate the source signals only up to a permutation, and a complex scaling factor can be exchanged between a source and the respective column of the mixing matrix [8]. For getting rid of this ambiguity, a short preamble sequence is used, consisting of N_{pr} training symbols b_{km} ($m = 1, 2, \dots, N_{pr}$) of the desired user k . The preamble is used for both conventional matched filter based channel estimation [20], and for identifying the desired information bearing source among the sources estimated by ICA. More specifically, this takes place by matching the preamble sequence of the desired user with the corresponding portions of the symbols estimated using RAKE for all the separated sources:

$$I_k = \arg \max_l \left\{ \sum_{m=1}^{N_{pr}} \text{dist}_H[b_{km}, \hat{b}_{km}^l] \right\}, \quad l = 1, \dots, N_s \quad (13)$$

Here I_k is the selected source index, N_s is the number of separated sources after whitening and ICA filtering, and $\sum_{m=1}^{N_{pr}} \text{dist}_H[b_{km}, \hat{b}_{km}^l]$ computes the Hamming distance between the preamble symbol sequence b_{km} and the corresponding estimated symbols \hat{b}_{km}^l for the l th source.

The Hamming distance for two binary symbols is one if they are equal, otherwise it is zero⁴. Hence the maximum of Hamming distance for two sequences of N_{pr} symbols in (13) is equal to N_{pr} . The best matching source which provides the maximum of the Hamming distances is assumed to be the source of interest, namely the signal corresponding to the desired user.

Finally, conventional detection is performed for the data of the selected source I_k . This leads to the basic ICA-RAKE receiver structure, where the well-known and robust RAKE method [12], [20] is used for conventional detection. We could have tried methods developed for multiuser detection [19] instead of RAKE, but in this work the prime interest was to study the capability of ICA to mitigate jammer signals prior to the actual detection.

However, the basic ICA-RAKE receiver described above as well as the BSS method proposed in [2] are still somewhat impractical as such. This is because they employ an ICA or BSS block even though it may not always be desirable. In fact, if the jammer signal is weak or even absent, the additional ICA or BSS jammer suppression block might even cause additional interference to the information bearing signal. Therefore, we improve the basic ICA-RAKE receiver by introducing two different switching strategies, pre- and post-switching schemes, which select either ICA-assisted or

⁴The Hamming distance is conventionally called distance even though it is actually a similarity measure.

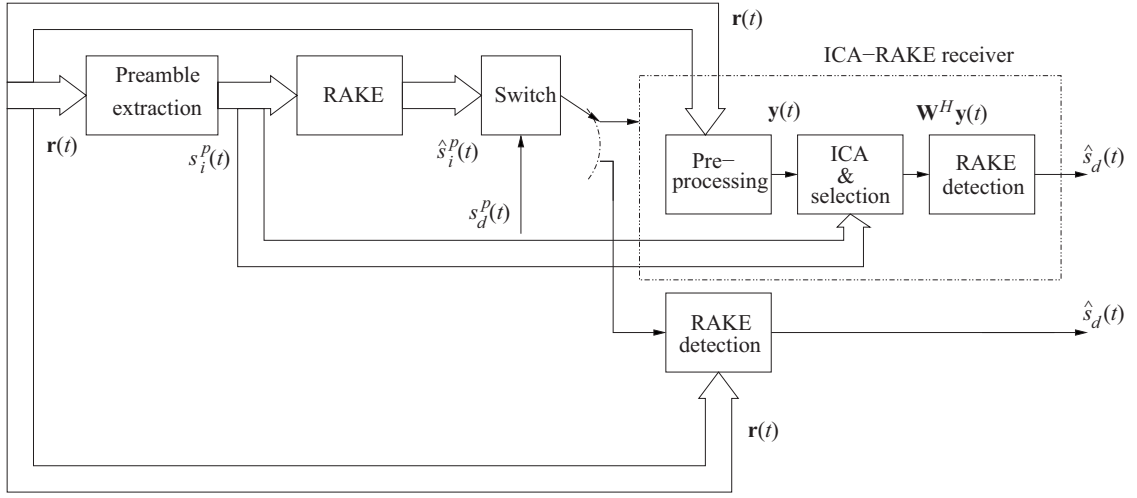

Fig. 1. ICA-RAKE pre-switching configuration. The preamble sequence s_d^p is used for switching between the two sections, and \mathbf{W} is the orthogonal separating matrix applied to the whitened version $\mathbf{y}(t)$ of the received vector $\mathbf{r}(t)$.

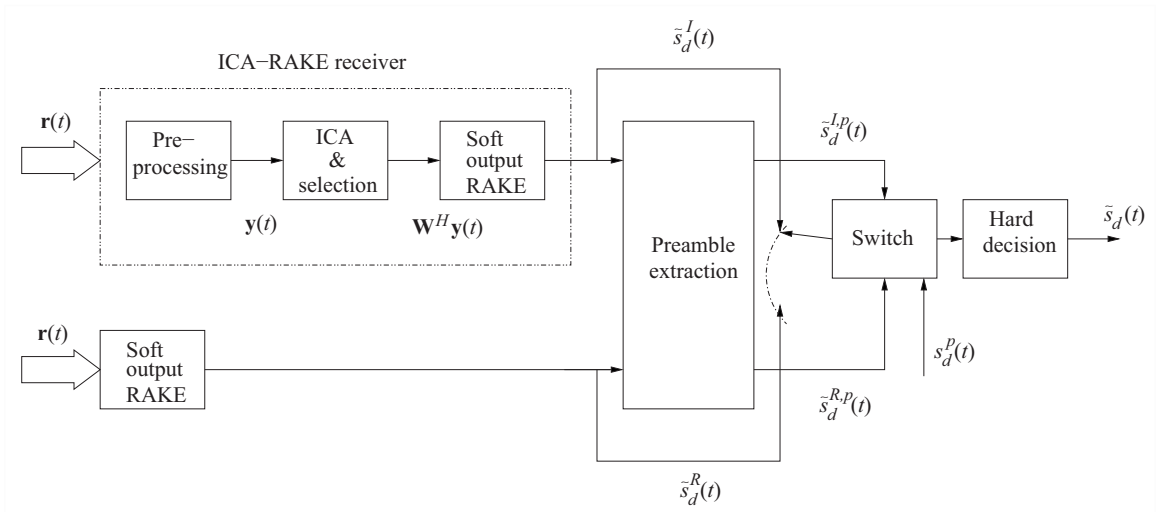

Fig. 2. ICA-RAKE post-switching configuration.

conventional RAKE detection in the array receiver chain.

The training symbols in the preamble can be used also to determine whether the additional jammer suppression by ICA is desirable or not. In general, this decision can be made either before or after ICA has been applied, see Figures 1 and 2 respectively. In the pre-switching scheme of Fig. 1, the switch decides whether there is a need to separate the jammer signal by ICA prior to conventional detection, or should conventional detection alone be performed. This decision is based on the performance of the RAKE detector on the preamble sequence b_{km} ($m = 1, 2, \dots, N_{pr}$). RAKE alone is applied if sufficiently many symbols in the preamble are detected correctly:

$$N_{pr} - \max_{l=1, \dots, N_s} \left\{ \sum_{m=1}^{N_{pr}} \text{dist}_H[b_{km}, \hat{b}_{km}^l] \right\} < \delta_{sw} N_{pr} \quad (14)$$

where δ_{sw} is the chosen threshold value for switching. In the post-switching scheme of Fig. 2, both ICA-RAKE and RAKE branches are first active. ICA-RAKE branch provides tentative

estimate \tilde{b}_{km}^I for the m th soft symbol of the desired user k , and RAKE branch respectively tentative soft symbol estimate \tilde{b}_{km}^R . The hard decision and thus the final estimate for all the symbols \hat{b}_{km} , $m = 1, \dots, M$, is selected from the branch which provides higher correlation with the training symbols.

V. EXPERIMENTAL RESULTS

We have tested the proposed ICA-RAKE methods and compared them with other methods using simulated DS-SS-CDMA downlink data with AWGN channel [20], [19], with a known path delay. Due to the AWGN channel a one-finger RAKE, or matched filter, is used. A simulated system with $K = 8$ users was considered, spread with short Gold Codes of length $C = 31$ [12], [20]. The length of the data block was $M = 200$ or $M = 5000$ QPSK symbols. The monitored user was chosen randomly, and the signal-to-noise ratio (SNR) and the signal-to-jammer ratio (SJR) were defined with respect to this desired user. The probability that a bit is jammed was chosen to be $p = 0.5$. The number of elements N_a in the uniform linear array (ULA) antenna varied from 1 to 3.

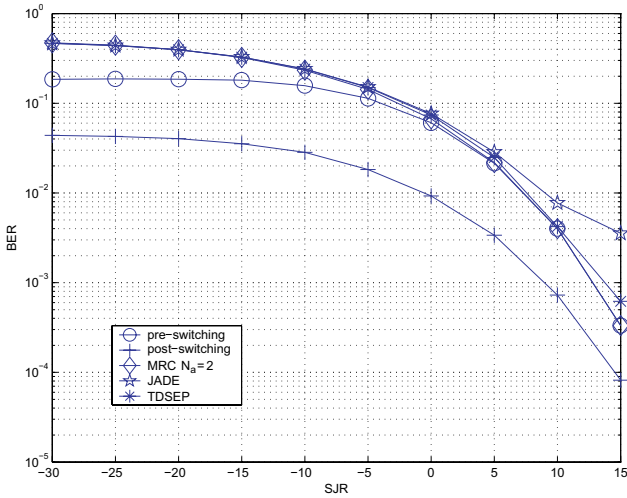

Fig. 3. Bit-error-rate as a function of SJR at an average SNR = 20 dB. This system had $K = 8$ users of equal strength in an AWGN channel with a bit-pulsed jammer, that had a frequency offset. The antenna was a 2 element array.

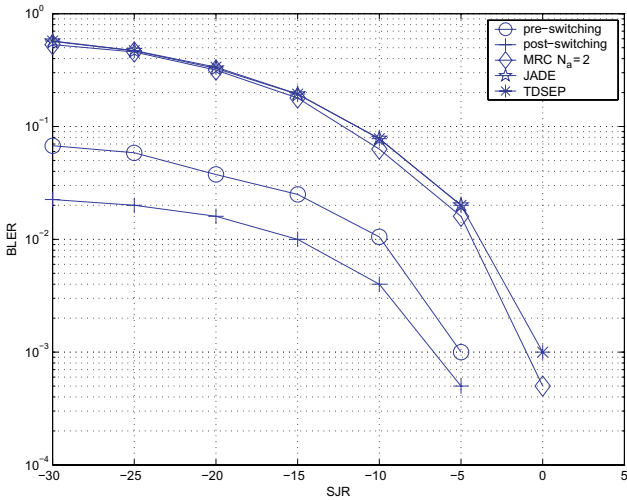

Fig. 4. Block-error-rate as a function of SJR at an average SNR = 20 dB. This system had $K = 8$ users of equal strength in an AWGN channel with a bit-pulsed jammer, that had a frequency offset. The antenna was a 2 element array.

The results are based on 2000 independent runs. They were compared with the conventional detector for a single antenna, and with the maximum ratio combining (MRC) method [12] for multiple antennas.

We first present some experimental results on the ICA-RAKE model with pre- and post-switching. The SJR of the pulsed jammer (with a frequency drift) was varied, and the achieved bit-error-rate (BER) as well as block-error-rate (BLER) were calculated. The results are shown respectively in Figs. 3 and 4. Figure 3 indicates that the two-antenna ICA-RAKE combination (both pre-switching and post-switching) performs better than MRC when the jamming is high. Since pre-switching involved activation of the ICA-RAKE branch only if more than 10% of the training symbols were erroneously estimated by RAKE, as the contribution of the jammer falls below 0 dB (in SJR), the activated branch is mostly RAKE, and hence the performance is similar to RAKE.

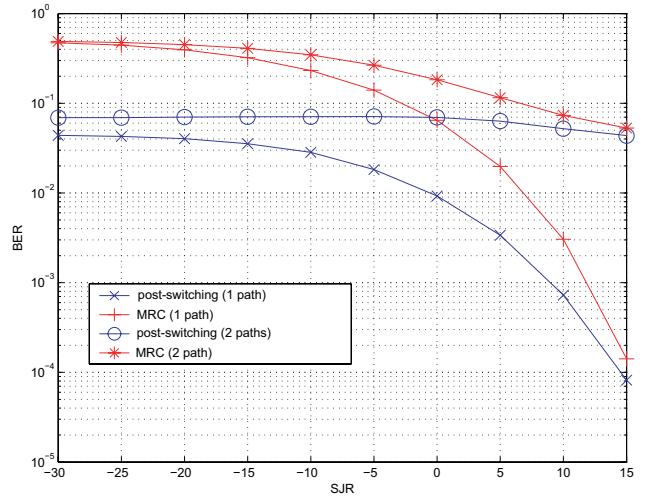

Fig. 5. Bit-error-rate as a function of SJR. This system had $K = 8$ users of equal strength in $L = 1, 2$ path system. The interference was a bit pulsed jammer that was locked to the carrier. The number of antenna sensors in each array was 2 (resp. 3) for single-path (resp. multi-path) case.

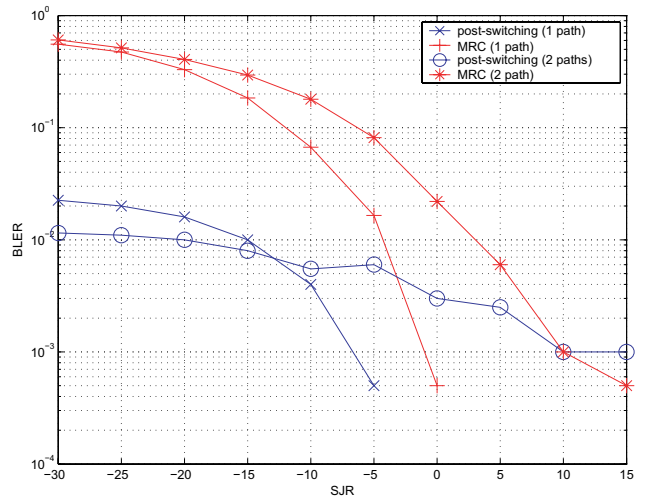

Fig. 6. Block-error-rate as a function of SJR. This system had $K = 8$ users of equal strength in $L = 1, 2$ path system. The interference was a bit pulsed jammer that was locked to the carrier. The number of antenna sensors in each array was 2 (resp. 3) for single-path (resp. multi-path) case.

Up to about -5 dB SJR, pre-switching outperforms MRC. Similarly, post-switching involves delayed decisioning, where the soft decision outputs of the ICA-RAKE branch or the RAKE branch are decoded based on the correlation with the training sequence. ICA-RAKE post-switching is an order of magnitude better than MRC. Both these methods also provide better performance when compared with other blind source separation methods like JADE [5] and TDSEP [21]. The coded block error rates (BLER) are presented in Fig. 4, in which it is assumed that a block is correct if 95%⁵ of the bits within the block are correct. Due to this definition we actually see from the figure how the bit errors are differently distributed over the blocks: even though the overall BERs of MRC and ICA-assisted methods might sometimes be rather similar, the erroneous bits are distributed over a much smaller set of blocks when ICA-assisted methods are used. This is why BLER of

⁵The BLER results for 98% and 99% thresholds are qualitatively the same.

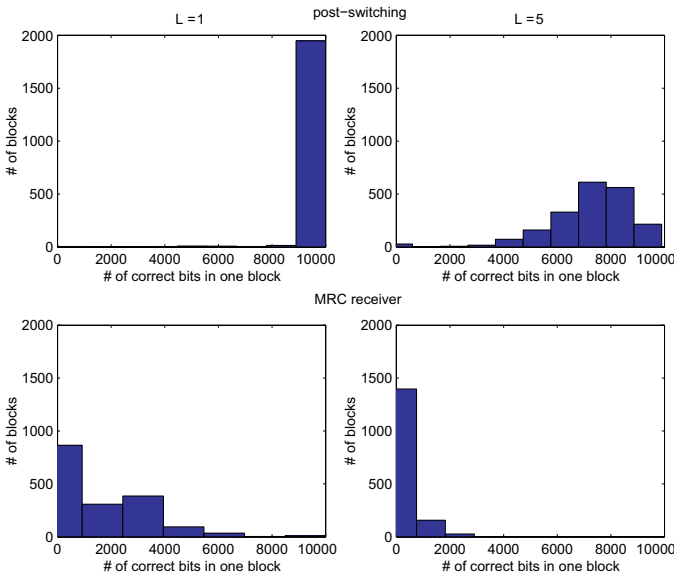

Fig. 7. Distribution of correct bits for both the methods for $L = 1$ (left) and $L = 5$ (right) paths. Simulation set up is similar to the previous ones. ICA-RAKE post-switching has more than 95% correct in most block for $L = 1$ while most blocks have at least 70% correct bits with $L = 5$ paths.

ICA-assisted method is constantly better than that of MRC in Fig. 4.

Consider now, a set up involving multiple paths. The system had up to $L = 5$ multipaths. Fig. 5 shows the bit error rates for a channel having 2 paths. ICA-RAKE post-switching was used. The interference was now a bit-pulsed jammer which was locked to the carrier. ICA-RAKE post-switching suppresses the interference for both the paths. Even at -30 dB (in SJR), the BER obtained after post-switching is considerably better than that obtained by MRC. Fig. 6 shows the block error rates for the above case. The effect of suppressing the jammer can be clearly seen in the block error rate curves. With a target block error rate of 10^{-2} , post-switching is significantly better than simple MRC. Also, the decrease in performance due to multipath is not significant.

Finally, consider the distribution of correct bits for an $L = 1$ and an $L = 5$ path channel in Fig. 7. The SJR was -30 dB. The upper figures are for post-switching while the figures at the bottom are for a conventional RAKE/MRC receiver. With a single path, post-switching detects most blocks with around 95% correct bits. As the number of paths increase, the results drift slowly to the left. Even with $L = 5$, ICA-RAKE provides around 65% of the blocks with at least 70% correct bits. With MRC receiver, the scenario is quite opposite. Even with a single path, the performance is average. As the number of paths increase, more blocks have a high number of erroneous bits.

More experimental results in different jamming scenarios,

especially for the basic ICA-RAKE receiver, can be found in our preliminary conference papers [13], [14], [17], [18].

ACKNOWLEDGMENTS

This work has been funded by the Telectronics programme of the Academy of Finland, and the European Commission project BLISS.

REFERENCES

- [1] M. Amin and Y. Zhang, "Interference suppression in spread spectrum communication system," in J. Proakis (Ed.), *The Wiley Encyclopedia of Telecommunications*. Wiley, 2002.
- [2] A. Belouchrani and M. Amin, "Jammer mitigation in spread spectrum communications using blind source separation," *Signal Processing*, vol. 80, pp. 723-729, 2000.
- [3] A. Belouchrani and M. Amin, "A two-sensor array blind beamformer for direct sequence spread spectrum communications," *IEEE Trans. Signal Processing*, vol. 47, pp. 2191-2199, Aug. 1999.
- [4] E. Bingham and A. Hyvärinen, "A fast fixed-point algorithm for independent component analysis of complex-valued signals," *Int. J. of Neural Systems*, vol. 10, pp. 1-8, 2000.
- [5] J.-F. Cardoso and A. Souloumiac, "Blind beamforming for non Gaussian signals," *IEE Proceedings-F*, vol. 140, no. 6, pp. 362-370, 1993.
- [6] G. Giannakis, Y. Hua, P. Stoica, and L. Tong (Eds.), *Signal Processing Advances in Wireless and Mobile Communications, Vol. 2: Trends in Single- and Multi-User Systems*. Prentice-Hall, 2001.
- [7] S. Haykin (Ed.), *Unsupervised Adaptive Filtering, Vol. 1: Blind Source Separation*. Wiley, 2000.
- [8] A. Hyvärinen, J. Karhunen, and E. Oja, *Independent Component Analysis*. Wiley, 2001.
- [9] J. Laster and J. Reed, "Interference rejection in digital wireless communications," *IEEE Signal Processing Mag.*, vol. 14, no. 3, pp. 37-62, May 1997.
- [10] U. Madhow, "Blind adaptive interference suppression for direct-sequence CDMA," *Proc. of the IEEE*, vol. 86, pp. 2049-2069, Oct. 1998.
- [11] L. Milstein, "Interference rejection techniques in spread spectrum communications," *Proc. of the IEEE*, vol. 66, pp. 657-671, June 1988.
- [12] J. G. Proakis, *Digital Communications*, 3rd ed. McGraw-Hill, 1995.
- [13] K. Raju, T. Ristaniemi, and J. Karhunen, "Suppression of bit-pulsed jammer signals in DS-SS array systems using independent component analysis," in *Proc. IEEE Int. Symposium on Circuits and Systems (ISCAS2002)*, May 2002, pp. I-189/I-192.
- [14] K. Raju and T. Ristaniemi, "ICA-RAKE switching for jammer cancellation in DS-SS array systems," in *Proc. IEEE Int. Symp. on Spread Spectrum Techniques and Applications (ISSSTA'02)*, Sept. 2002, pp. 638-642.
- [15] T. Ristaniemi and J. Joutsensalo, "Advanced ICA-based receivers for DS-SS systems," in *Proc. of the IEEE Int. Conf. on Personal, Mobile, and Radio Communications (PIMRC)*, Sept. 2000, pp. 276-281.
- [16] T. Ristaniemi and J. Joutsensalo, "Advanced ICA-based receivers for block fading DS-SS channels," *Signal Processing*, vol. 82, pp. 417-431, 2002.
- [17] T. Ristaniemi, K. Raju, and J. Karhunen, "Jammer mitigation in DS-SS array system using independent component analysis," in *Proc. IEEE Int. Conf. on Communications (ICC2002)*, Apr. 2002.
- [18] T. Ristaniemi, K. Raju, J. Karhunen, and E. Oja, "Jammer cancellation in DS-SS arrays: pre and post switching of ICA and RAKE," in *Proc. of the 2002 IEEE Workshop on Neural Networks for Signal Processing*, Sept. 2002, pp. 495-504.
- [19] S. Verdú, *Multisuser Detection*. Cambridge University Press, 1998.
- [20] A. Viterbi, *CDMA: Principles of Spread Spectrum Communications*. Addison-Wesley, 1995.
- [21] A. Ziehe and Klaus-Robert Müller, "TDSEP - An efficient algorithm for blind separation using time structure," in *Perspectives in Neural Computing*, pp. 675-680, 1998.